



Ministry of Defence

INTERIM

Defence Standard

00-25 (PART 11) / Issue 1 31 August 1988

HUMAN FACTORS

FOR DESIGNERS OF EQUIPMENT

PART 11 : DESIGN FOR MAINTAINABILITY

AMENDMENTS ISSUE SINCE PUBLICATION

AMD NO	DATE OF ISSUE	TEXT AFFECTED	SIGNATURE & DATE

Revision Note

Historical Record

This Defence Standard has its origins in the 2-volume handbook "Human Factors for Designers of Naval Equipment" published in 1971.

Arrangement of Defence Standard 00-25

The arrangement of the Parts comprising Def Stan 00-25 is shown below:

- Part 1: Introduction
- Part 2: Body Size
- Part 3: Body Strength and Stamina
- Part 4: Workplace Design
- Part 5: Stresses and Hazards
- Part 6: Vision and Lighting
- Part 7: Visual Displays
- Part 8: Auditory Information
- Part 9: Voice Communication
- Part 10: Controls
- Part 11: Design for Maintainability
- Part 12: Systems

Two or more Parts may apply to any one equipment and it is, therefore, essential that all Parts be read and used where appropriate.

HUMAN FACTORS FOR DESIGNERS OF EQUIPMENT

PART 11: DESIGN FOR MAINTAINABILITY

PREFACE

i This Part of this Defence Standard presents descriptive detail, technical data and diagrams relating to some of the important issues concerned with the human factors concept in maintainability and the maintainers requirements for maintenance.

ii This Defence Standard has been prepared under the auspices of the Steering Committee on the Tri-Service Human Factors Handbook (SCOTSH) consisting of MOD human factor specialists chaired by Senior Psychologist (Naval). This Part of this Defence Standard, has been edited by a Working Group chaired by Head of Human Factors Research Section, Behavioural Science Division, Admiralty Research Establishment, Teddington.

iii This Standard should be viewed as a permissive guideline, rather than as a mandatory piece of technological law. Where safety and health is concerned, particular attention is drawn to this Standard as a source of advice on safe working limits, stresses and hazards etc. Use of this Standard in no way absolves either the supplier or the user from statutory obligations relating to health and safety at any stage of manufacture or use.

iv Users of this Standard shall note that some material may be claimed to be subject to copyright in this or other countries. Copyright where known is acknowledged.

v This Standard has been devised for the use of the Crown and of its contractors in the execution of contracts for the Crown and, subject to the Unfair Contract Terms Act 1977, the Crown will not be liable in any way whatever (including, but without limitation, negligence on the part of the Crown, its Servants or agents) where the Standard is used for other purposes.

vi This Standard has been agreed by the authorities concerned with its use and shall be incorporated whenever relevant in all future designs, contracts, orders etc and whenever practicable by amendment to those already in existence. If a difficulty arises which prevents application of the Defence Standard, the Directorate of Standardization shall be informed so that a remedy can be sought.

vii Any enquiries regarding this Standard in relation to an invitation to tender, or a contract in which it is invoked, are to be addressed to the responsible technical or supervising authority named in that invitation to tender or contract.

viii This Defence Standard is being issued as an INTERIM Standard and is provisional in order to obtain information and experience of its application. This will then permit the submission of observations and comments from users, using D Stan Form No 22 enclosed.

<u>CONTENTS</u>	<u>PAGE</u>
Preface	1
0 Introduction	3
1 Scope	3
2 Related Documents	3
3 Definitions	3
4 Maintainability	3
5 Environmental Conditions	6
6 Layout of Units	7
7 Designing for Human Maintenance	7
8 Maintainability and Maintenance Checklists	13
Annex A Related Documents	A-1
Figure 1 Human Factors at the design stage	6
Figure 2 Unit attachment	8
Figure 3 Unit identification	8
Figure 4 Case design	11
Table A Handle Clearance Dimensions (mm)	9
Table B Recommended Height/Weight Lift Limits	10
Table C Maintenance Access Dimensions	12
Table D Maintainability Requirements Check List	13
Table E Maintenance Design Factors Check List (adapted from Salvendy)	14

HUMAN FACTORS FOR DESIGNERS OF EQUIPMENT

PART 11: MAINTAINABILITY

0 Introduction

The main aim of this Part of the Standard is to help designers to be aware of the human factors in the maintenance concept within the pre-design requirements of a project.

For the purpose of this STANDARD the hierarchical terms are:

The highest level:	Materiel/Equipment/System	An "Item" could be any of these.
	Unit/Subsystem	
the lowest level:	Component/Part	

1 Scope

This Part of the Standard provides information and guidance on the requirements of the human in maintenance of equipment. Also some of the elements that should be considered at the design stage affecting the maintainer as a User are described.

2 Related Documents

2.1 The documents referred to in this Part of the Standard, together with additional publications providing greater coverage on particular aspects of the subject, are listed in annex A.

2.2 Reference in this Standard to any related documents means in any invitation to tender or contract the edition and all amendments current at the date of such tender or contract unless a specific edition is indicated.

3 Definitions

3.1 For the purpose of this Part of the Defence Standard the following definitions apply.

3.2 Maintainability. The ability to carry out rapid and reliable system restoration, using ordinary trained people and reasonable support facilities to maintain the equipment at a specified level of performance.

3.3 Maintenance. All activities necessary to keep materiel in, or restore it to, a specified condition.

4 Maintainability

4.1 The designer should design with maintainability in mind, so that maintenance may be carried out as far as possible in an efficient and user friendly manner.

4.2 The following are the aspects of maintainability and maintenance where human factors can start to be involved in the design concept.

Requirements	A statement of the principal means and frequency of preventing an item from failing or of restoring its function when it has failed.
Policy	A strategy within which decisions on maintenance are taken.
Management	The organization of maintenance within agreed policy.

4.2.1 Requirements. A complete statement of maintainability requirements to include maintenance and Human Factors should cover the following elements:

(a) A plan for Human Factors as an integral part of an equipment project from Staff Target through to acceptance into Service. The plan may include a maintainability design study supported by reviews (See Def Stan 00-40 and BS 6548). Figure 1 illustrates the human factors involvement and some of the tasks at the start of the design concept;

(b) maintainability characteristics to be achieved by the item design;

(c) constraints to be placed on the deployment which will affect the item's maintenance;

(d) maintainability programme requirements to be accomplished by the supplier to assure that the delivered item has the required maintainability characteristics;

(e) provision of maintenance support planning;

(f) expected population type training level for maintainers and the number of maintainers required at set levels;

(g) type of maintenance for set levels;

(h) test equipment, tooling, handbooks, diagrams, instructions etc;

(j) a maintainability specification, detailing the requirements and the method of achieving them, to include proper references to definitions of terms used and, as needed, a list of special terms.

4.2.2 Policy The following questions that affect maintenance strategy should be asked:

(a) preventive maintenance: Is preventive maintenance in the form of servicing a design feature?;

(b) front line maintenance: Who does the front line maintenance when an item breaks down in the middle of nowhere?;

(c) repair: How is the item repaired or restored to service? Is the defective part scrapped or returned for repair?;

(d) maintenance history: Has the maintenance history of previous similar equipment been studied for answers to human factors problems and will "what happened" and "when" be recorded?;

(e) spares support: Are spares to be supplied and carried with the 'unit in service?

4.2.3 Management. The following questions that affect the maintenance management should be considered at the design stage:

(a) requirements: How, what, when and by whom is maintenance to be carried out at required levels?;

(b) instructions: Do they state in terms understood by the maintainer how to keep the item working?;

(c) schedules: Are these realistic in what is to be done and when?;

(d) programme: Does it state what time is allocated for doing maintenance?;

(e) parts list: Does it identify what parts make up the item and the quantities?;

(f) planning: Does it consider what is required so that it can be at the right place, in time and in the correct quantity?;

(g) history: Is it recorded what has been done, when and how this will be of use in the maintenance review?

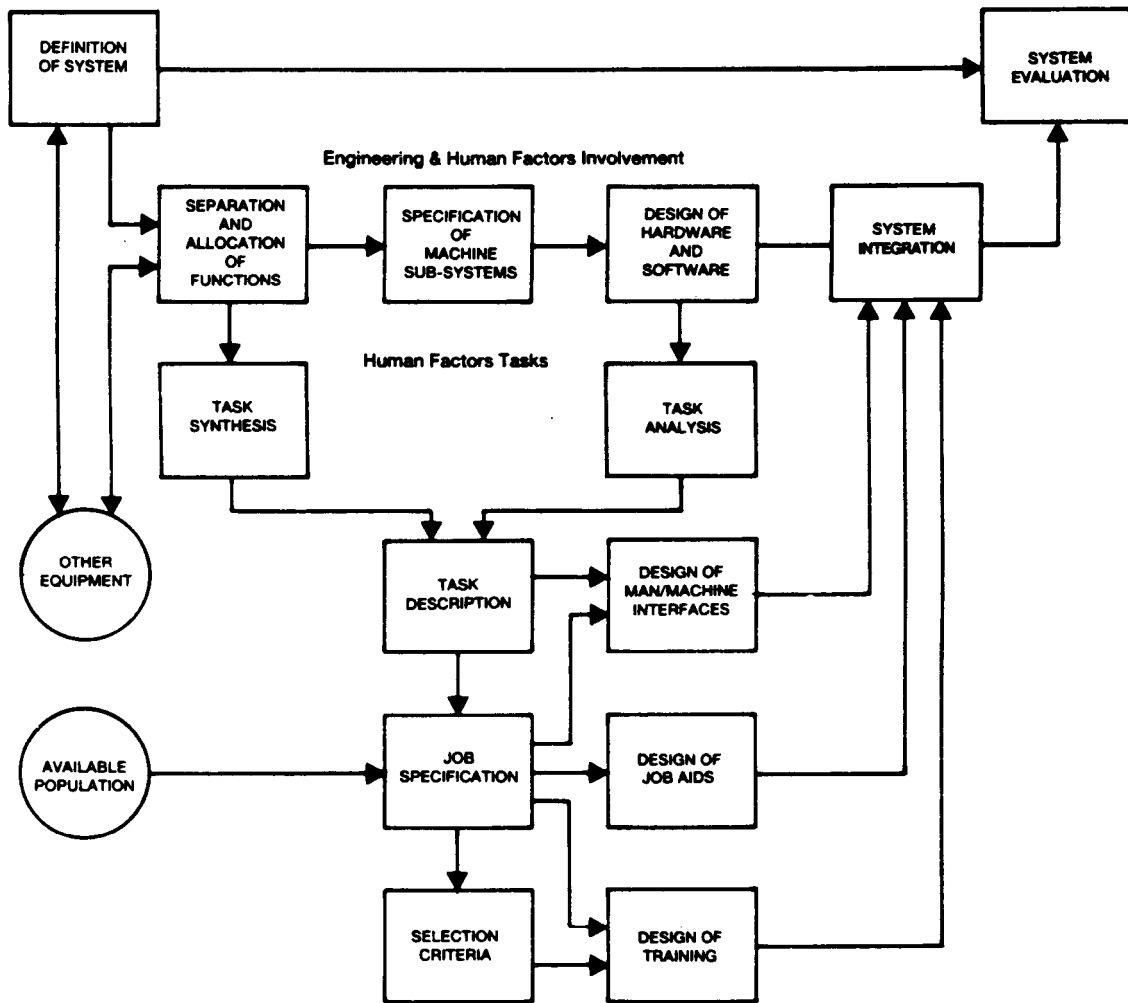

Figure 1. Human Factors at the design stage

5 Environmental Conditions

The equipment should permit maintenance to be carried out on site under specified extreme environmental and operational conditions such as:

- (a) the need to wear protective clothing: This will require a more generous allowance of space. (See part 2 of this Standard);
- (b) high/low temperature and humidity: This will demand larger control knob size suitable for use with protective clothing or surface texturing to reduce the effect of perspiration. (See Part 10 of this Standard);
- (c) inadequate lighting: This may require the provision of a supplementary lighting supply so that the task can be seen. (See Part 6 of this Standard);
- (d) the need to avoid hazards: Access for maintenance may expose personnel to hazards (see Part 5 of this Standard) or operating conditions such as high temperature or electrically live components;

6 Layout of Units

6.1 The maintainer is a user and as such should be considered at the design stage, he/she will require:

(a) space to work, in and around the equipment: This should be a separate area from the normal user area; (see Part 4 of this Standard);

(b) adequate lighting to illuminate the task: This will require the provision of a light source in the equipment or a supplementary supply, (see Part 6 of this Standard);

(c) access to the subassemblies or components: Consider whether the following may have to pass through the space:

(i) the maintainer's hand, arm, head/torso, himself;

(ii) tools, components or subassemblies, (see Parts 2 & 10 of this Standard);

(iii) a combination of the above.

6.2 Unit access. This should be planned, tidy and functional with provision for:

(a) pull-out/roll-out approach capability for maintenance;

(b) suitable designated areas for working diagrams and the placement of test equipment and/or handbooks etc. (See Part 4 of this Standard);

(c) identified and easy access for short life items that require frequent replacement.

6.3 Safety measures. The design of the equipment should be such that adequate safety protection, conforming to statutory Health and Safety regulations, comes into operation when it is opened for maintenance. Examples being:

(a) emergency shutdown/stop device (the use of which must be considered);

(b) electrical cut-out switches;

(c) lockable controls;

(d) warning signs or guards, which should be incorporated if the equipment needs to be live or working when opened up.

7 Designing for Human Maintenance

7.1 Every item in the system will at some time in its life require to be maintained, some more frequently than others. To the maintainer this means that it should be accessible and/or removable from the equipment for some level of maintenance.

7.2 Unit attachment. If necessary, runners should be attached to the equipment to allow it to be rolled-out for maintenance. In such instances the use of extended wiring, flexible piping and trunking would be beneficial. Adequate clearance for the runners is to be ensured. An example is shown in Figure 2.

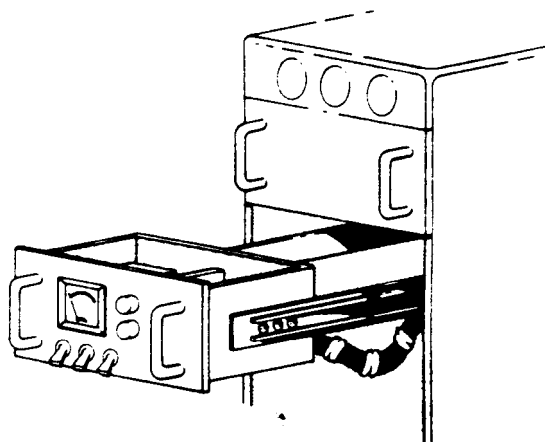

Figure 2. Unit Attachment

7.3 Unit identification. All essential details should be easily and visually identified when in position. An example is shown in Figure 3 (see also Part 7 of this Standard).

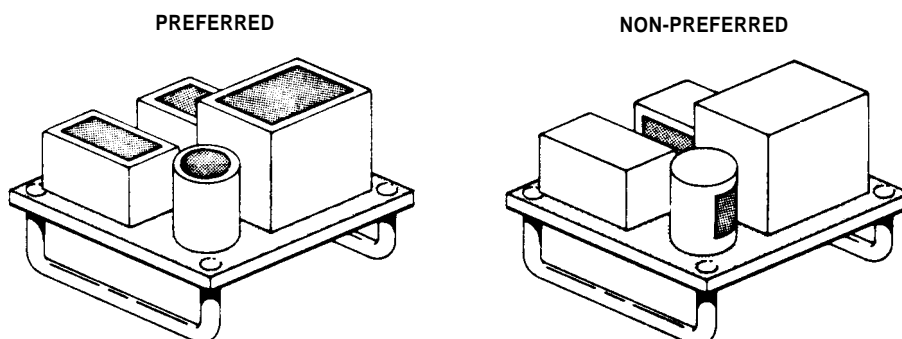

Figure 3. Unit Identification

7.4 Unit handling/portability. During the design stage consideration should be given as to how a unit or component is to be lifted or moved during maintenance and whether its size makes it easily portable.

7.4.1 Use of handles for lifting. Units which need to be removed for any purpose should be provided with handles whenever their omission might lead to damage to the unit or difficulty during removal or replacement. The use of handles for the following weights are for guidance purposes only and are only applicable when unrestricted access is available.

(a) loads less than 10 kg: the advantage of handles could be considered;

(b) loads between 10-20 kg: handles are desirable;

(c) loads in excess of 20 kg: handles are essential. (Loads in excess of 60 kg require mechanical lifting attachment).

7.4.2 Positioning of handles. Handles should be positioned such that:

- (a) single handles are placed over the centre of gravity;
- (b) two or more handles are equidistant from the centre of gravity;
- (c) they do not interfere with operation or maintenance;
- (d) at least 75 mm clearance exists between handle and obstructions. (See table A for handle clearance for use with bare/clothed hand);
- (e) units can be drawn from racking by the handle, held comfortably and carried without interference when walking.

Table A

Handle Clearance Dimensions (mm)

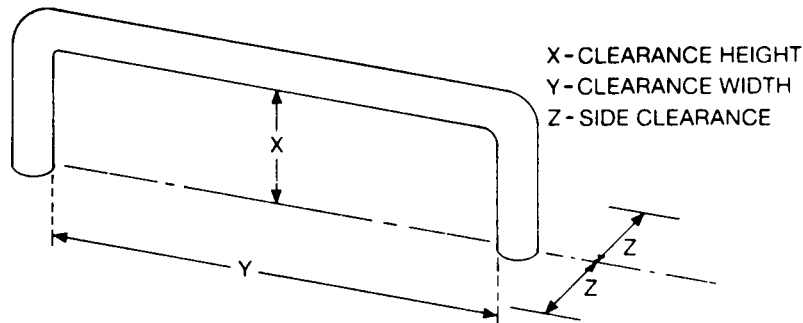

TYPE OF HANDLE	Bare hand			Gloved Hand			Arctic Mitten		
	X	Y	Z	X	Y	Z	X	Y	Z
Bars									
Two fingers	32	64	38	38	76	38	Do not use		
One hand	50	108	50	64	120	50	100	140	100
Two hand	50	216	50	64	240	50	100	280	100
T-bars	38	100	38	50	115	50	Do not use		
J-bars	50	100	50	50	115	50	100	127	100
Recesses									
Finger tip	20 dia		13	25 dia		20	Do not use		
Two finger	32	64	50	38	76	50	Do not use		
One hand	50	108	50	64	120	75	100	140	100

7.4.3 Additional uses for handles. Handles, as well as for lifting, may be utilized for the following purposes:-

- (a) prevention of accidental operation of controls;
- (b) protection for easily broken parts such as instrument faces;
- (c) to serve as locking devices to secure components in place;
- (d) to act as protective supports or stands.

7.5 Unit lift. The lift height/weight limits will determine whether it is a one or two man lift. One man lifts are preferred. (See table B.) The designer should bear in mind the relative positions of the maintainer(s) and unit at the start/finish of the lift (see Parts 4 and 5 of this Standard). This will assist in determining the provision of the correct shaped handles or lifting/securing fixtures and their positioning.

Table B
Recommended Height/Weight Lift Limits

Height (mm)						
Weight (kg)	0-305	306-610	611-915	916-1220	1221-1525	1526-1830
0 - 6.8	1	1	1	1	1	1
6.9 - 9.1	1	1	1	1	1	2
9.2 - 11.4	1	1	1	1	2	2
11.5 - 13.6	1	1	1	2	2	2
13.7 - 15.9	1	1	1	2	2	Use Mechanical List (label as such)
16.0 - 18.2	1	1	2	2	2	
18.3 - 20.5	1	1	2	2	2	
20.6 - 40.8	2	2	2	2		

NOTE: 1 = One man lift.
2 = Use two men to lift, label as such and provide handles.

7.5.1 Cased Units. The case should lift off the unit, not the other way round, see figure 4.

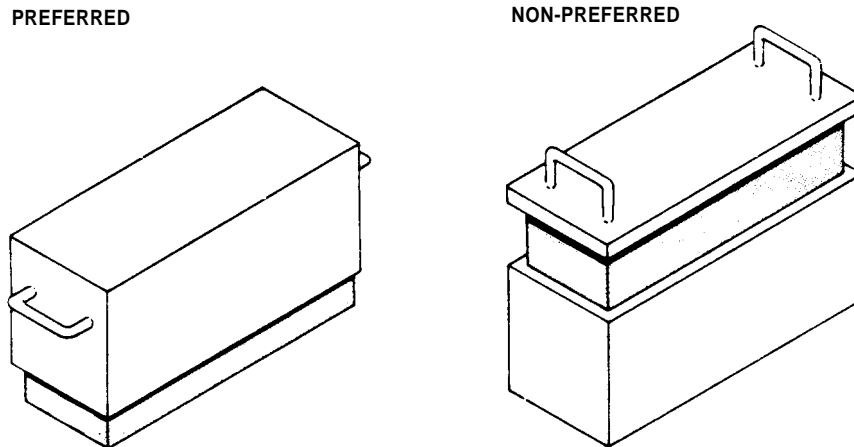

Figure 4. Case Design

7.6 Maintenance tooling and test equipment. The designer should consider:

- (a) the tooling and test equipment required for maintenance including visual control/monitoring;
- (b) the space required to fit and see/use tooling and test equipment;
- (c) the use of standard tooling.

7.7 The use of access fasteners. Standardization in the use of fasteners should be considered for the whole equipment by using common types and standard sizes, also:

- (a) access fasteners should be kept to a minimum, within safety limits;
- (b) the use of hand-operated access fasteners is preferred where possible;
- (c) captive nuts and/or bolts must be used if dropping such items might cause damage or where assembling or dismantling would otherwise be difficult.

7.8 Access to the components. The designer should consider whether:

- (a) the component has to be adjusted/removed. Does this require the use of tooling, if so what tools?;
- (b) the space available is adequate for the tool to be fitted in place, held and used by the maintainer?;
- (c) the access is big enough for the removal of the component plus the maintainer's hand(s) holding it?;

7.8.1 Access dimensions. The designer should be aware of the environmental conditions where operational maintenance is likely to be required. The dimensions shown in Table C are for guidance purposes only with bare handed access.

7.8.2 Access for lubrication/servicing. The designer should consider how the unit is to be lubricated, replenished or replaced when part of a complete system:

- (a) components should be self lubricating;
- (b) the types of lubrication used in the system should be kept to a minimum;
- (c) it should be possible to lubricate components without dismantling them;
- (d) lubrication and replenishment points should be easily accessible and labelled as such within the system as a whole.

Table C

Maintenance Access Dimensions (mm)

Access for Maintenance	Aperture Dimension
Inserting an empty flat held hand	60 x 100 mm
Using a screwdriver with 25 mm dia handle	95 x 95 mm
Inserting a 50 mm dia connector with hand	100 x 100 mm
Inserting a box-shaped item with hand	width of item + 45 mm
Inserting a box-shaped item held by two hands at its sides	width of item + 115 mm
Inserting a square unit held by two handles	width of unit + 13 mm clearance on each side
Reaching into an access space to a depth of 150-600 mm	width of aperture at least depth of reach
Reaching at full arm's length (up to the shoulders)	width of aperture 500 mm x 100 mm minimum height plus the facility of line of sight

7.8.3 Servicing when system is live/working:

- (a) how will the item be made safe to work on? (see 6.3).
- (b) what will be required to isolate that item?
- (c) will the item require standby or back up arrangements to be made?
- (d) when the task is complete, what is required to return the system to normal working?

8 Maintainability and Maintenance Checklists

8.1 Check list of maintainability requirements. Some of the more important human factors subjects which could be specified at the design requirements stage are listed at table D.

TABLE D

Maintainability Requirements Check List

- | |
|---|
| <ol style="list-style-type: none">1 Maintenance skill level requirements.2 Need for special tools or test equipment.3 Need for adjustments.4 Parts standardization5 Clear subsystem function identification.6 Visual inspection access.7 Built-in test facilities8 Properly marked test points.9 Colour coding and labels as appropriate10 Use of plug-in units.11 Use of captive fasteners.12 Use of handles on replaceable units.13 Scope and range of technical manuals.14 Human factors limitations in the design of the item. |
|---|

(adapted from BS 6548)

8.2 Checklist of maintenance design factors. A maintenance review of the whole system design should consider the factors listed in table E.

TABLE E

Maintenance Design Factors Checklist (adapted from Salvendy)

Factors	have been considered				Remarks
	have not been considered	are satisfactory	are not satisfactory	.	
Accessibility (relative to maintenance items)					
1	Opening, panels and doors
2	Covers, plates and caps
3	Drawers, frames and slides
4	Internal work space/volume
5	Internal lighting and paint
6	Location, Arrangement
7	Other
Maintenance Items					
8	Test and service points
9	Cases, shields and guides
10	Interlocks, overrides and stop
11	Lines, cables and connectors
12	Disconnects, latches, catches
13	Fasteners, pins, safety wiring
14	Mounting and packaging
15	Controls and displays
16	Coding, labelling, and pathways
17	Parts, assemblies, modules
18	Fuses, circuit breakers
19	Other
Maintenance Steps and Processes					
20	Detection
21	Localization
22	Isolation
23	Correction and repair
24	Testing and verification
25	Removal and replacement
26	Inspection, servicing, cleaning
27	Adjustment, calibration
28	Other
Support Provisions					
29	Handling (powered) (manual)
30	Mobility and transportability
32	Test and service equipment
33	Tools and accessories
34	Spares, parts and material
35	Other

Related Documents

ISO 6385	Ergonomic Principles in the Design of Work Systems
BS 3811	Glossary of Management Terms in Terotechnology
BS 5304	Safety of Machinery
BS 6548	Maintainability of Equipment
Def Stan 00-05	Design Criteria for Reliability, Maintainability and Maintenance of Land Service Materiel
Def Stan 00-10	General Design and Manufacturing Requirements for Service Electronic Equipment
Def Stan 00-25	Human Factors for designers of equipment Part 1 Introduction Part 2 Body Size Part 3 Body Strength and Stamina Part 4 Workplace Design Part 5 Stresses and Hazards Part 6 Vision and Lighting Part 7 Visual Displays Part 8 Auditory Information Part 9 Voice Communication Part 10 Controls Part 12 Systems
Def Stan 00-40 (Part 1)/2 ARMP-1 (Part 2)/1 ARMP-2	Achievement of Reliability and Maintainability Management Responsibilities and Requirements for Programmed and Plans. General Application Guidance on the use of Part 1 (ARMP-1)
Def Stan 00-41	MOD Practices and Procedures for Reliability and Maintainability
US Military Documents	D1-H-7051: Human Engineering
Bond N A	Handbook of Human Factors (Chapter 103) edited by G Salvendy, published by John Wiley & Sons Ltd, Chichester P019 1UD (1986)
PP 7317	Ergonomics Standards & Guidelines for Designers, by Stephen Pheasant, published by BSI
Pheasant S T	Body Space: Anthropometry, Ergonomics & Design, published by Taylor & Francis, London (1986)
Sanders M S and McCormick E J	Human Factors in Engineering & Design published by McGraw-Hill

Blank Page

© Crown Copyright 1988

Published by and obtainable from:
Ministry of Defence
Directorate of Standardization
Kentigern House
65 Brown Street
GLASGOW G2 8EX

Tel No: 041-248 7890

This Standard may be fully reproduced except for sale purposes. The following conditions must be observed:

- 1 The Royal Coat of Arms and the publishing imprint are to be omitted.
- 2 The following statement is to be inserted on the cover:
'Crown Copyright. Reprinted by (name of organization) with the permission of Her Majesty's Stationery Office.'

Requests for commercial reproduction should be addressed to HOD Stan 1, Kentigern House, 65 Brown Street, Glasgow G2 8EX

The following Defence Standard file reference relates to the work on this Standard - D/D Stan/328/1/11.

Contract Requirements

When Defence Standards are incorporated into contracts users are responsible for their correct application and for complying with contract requirements.

Revision of Defence Standards

Defence Standards are revised when necessary by the issue either of amendments or of revised editions. It is important that users of Defence Standards should ascertain that they are in possession of the latest amendments or editions. Information on all Defence Standards is contained in Def Stan 00-00 (Part 3) Section 4, Index of Standards for Defence Procurement - Defence Standards Index published annually and supplemented periodically by Standards in Defence News. Any person who, when making use of a Defence Standard encounters an inaccuracy or ambiguity is requested to notify the Directorate of Standardization without delay in order that the matter may be investigated and appropriate action taken.



DIRECTORATE OF STANDARDIZATION (Stan 6b)
MINISTRY OF DEFENCE
 Room 5131
 Kentigern House 65 Brown Street Glasgow G28EX
 Telephone: 041 248 7890 Ext
 Direct Dialling 041-228 Ext

Your reference

 Our reference
 D/D stan/328/1/11
 Date
 18 September 1988

INTERIM DEFENCE STANDARD IMPROVEMENT PROPOSAL

Defence Standard No: 00-25/1 (PART 11)

Title: HUMAN FACTORS FOR DESIGNERS OF EQUIPMENT PART 11: DESIGN FOR MAINTAINABILITY

The above Defence Standard has been published as an INTERIM Standard and is provisional because it has not been agreed by all authorities concerned with its use. It shall be applied to obtain information and experience on its application which will then permit the ,Submission of observations and comments from users.

The purpose of this form therefore is to solicit any beneficial and constructive comment that will assist the author and/or committee to review the INTERIM Standard prior to it being converted to a normal Standard.

Comments are to be entered below and any additional pertinent data which may also be of use in improving the Standard should be attached to this form and returned to the Directorate of Standardization at the above address. No acknowledgement will normally be sent.

NAME .C..A..KENNEDY.....SIGNATURE *C.A. Kennedy*..... BRANCH: STAN6b...

1. Has any part of the Standard created problems or required interpretation during use:

YES NO if 'yes' state,

a. clause number/s and wording:

b. recommendation for correcting the deficiencies:

2. Comments on any requirement considered too rigid:

3. Is the Defence Standard restrictive:

YES NO (if 'yes' in what way)

4. General comment:

5. We agree that this INTERIM Standard (subject to amendments to take account of our comments) when published in final form will cover our requirements. Should you find our comments at variance with the majority, we shall be glad of the opportunity to enlarge upon them before final publication.

Signature Representing

Submitted by (print or type name and address):

Telephone number:

Date:

Our Ref:
